

# ASSEMBLY INSTRUCTIONS

1. Slide front panel (202) around the in-take pipe (106) through the slit (215), and rotate so the Velcro (212) is facing outside and up. Secure Velcro (216) by folding flap over Velcro.
2. Place side panels (204,208), ensuring that the Velcro is facing outside.
3. Secure panels (204,208) to front panel (202) by folding flap over Velcro.
4. Place back panel (206) over the pump motor (110), ensuring to free the bottom motor cooling openings.
5. Secure panels (204,208) to back panel (206) by folding flap over Velcro.
6. Place top panel (210) around the out-take pipe (108) through the slit (215). Secure Velcro (216) by folding flap over Velcro.
7. Secure top panel (210) to all panels by folding all flaps over Velcro.

**Note:** To inspect and perform routine maintenance to the skimmer basket, use lid (506) for models that have the option. Otherwise, remove the top panel.



For technical support call 760.736.4987 or email: [info@premierinnov.com](mailto:info@premierinnov.com)  
[www.premierinnov.com](http://www.premierinnov.com)

## Product Disclaimer

The purchaser of this product (the owner) is advised to check the status of existing warranties on the pool pump slated for noise suppression and to satisfy themselves as to the effect the installation of this passive noise-suppression cover will have on the existing pool pump warranty coverage.

This product has been successfully and thoroughly tested without incident, but as a post-market device, it is not recognized as an approved accessory by some pool pump manufacturers. This Pool Pump Noise Reducer system has been engineered and designed to compliment existing pool pump designs. It is imperative that the integrity of the original manufacturer's pool pump heat venting system remain intact. Pool pump cooling vents on the bottom of the motor casing are to remain free of blockage and closure of any kind.

Owners of this Pool Pump Noise Reducer are advised to inspect the cover periodically to ensure that such obstructions to the proper venting of the pool pump do not occur. Under no circumstances are the manufacturer and their representatives to be held liable for the improper installation of this product or for pool pump failures, regardless of the manner of installation, pool pump age, frequency of pool pump usage, and pool pump warranty status.

It is the pool pump owner's responsibility to see to it that the Pool Pump Noise Reducer cover is properly installed as per manufacturer's specifications.



For technical support call 760.736.4987 or email: [info@premierinnov.com](mailto:info@premierinnov.com)  
[www.premierinnov.com](http://www.premierinnov.com)

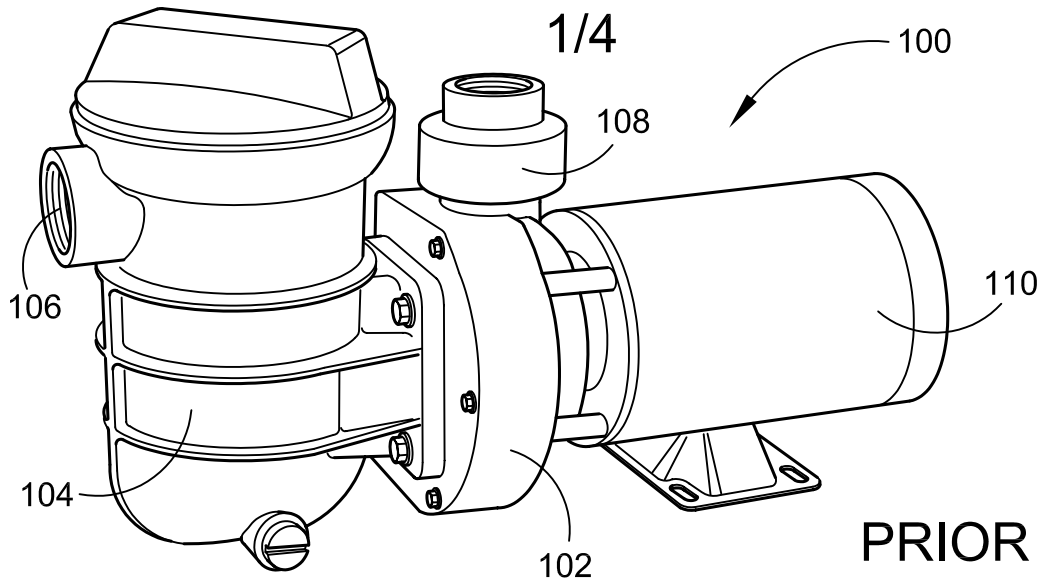

PRIOR ART  
FIG. 1

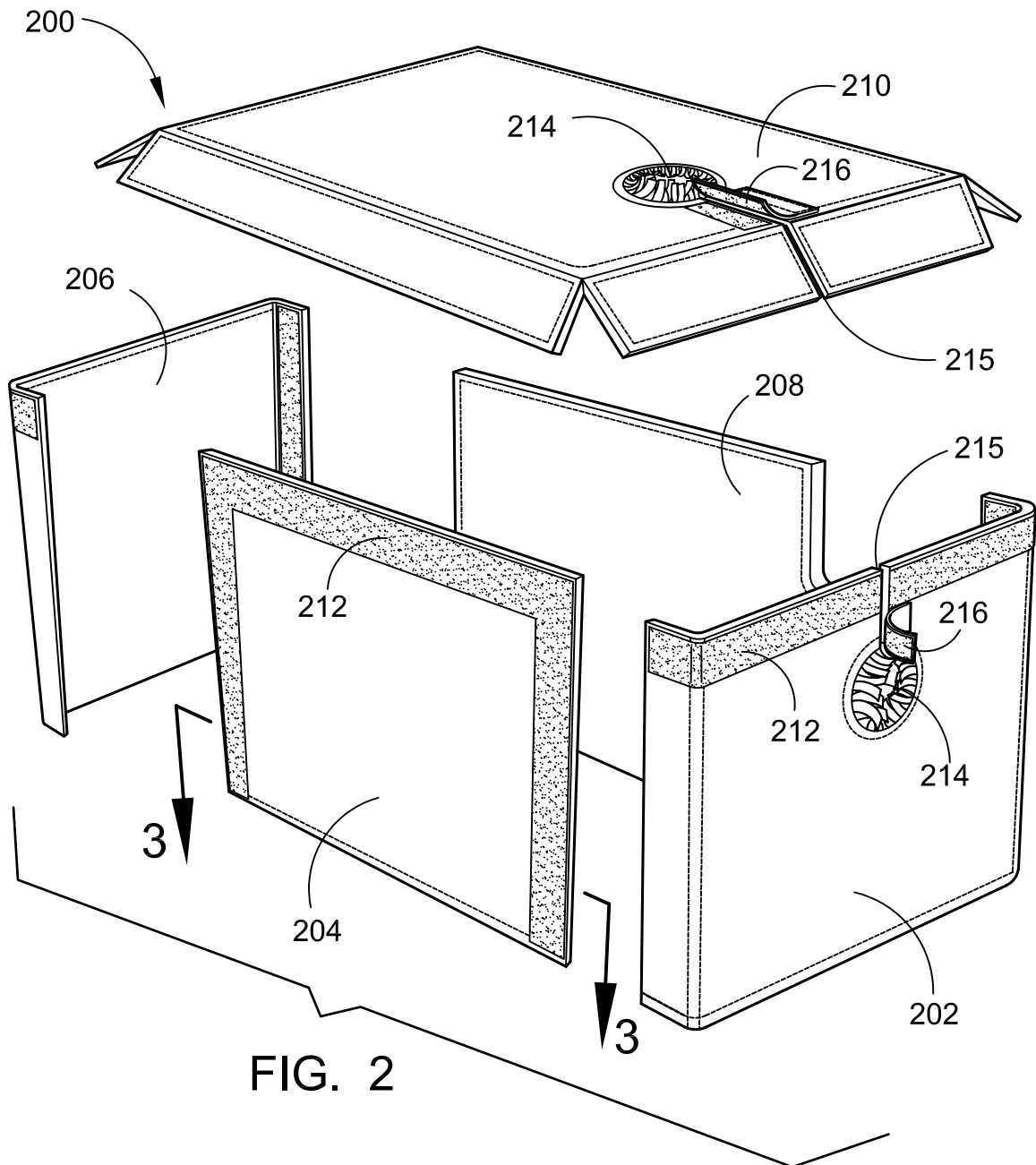
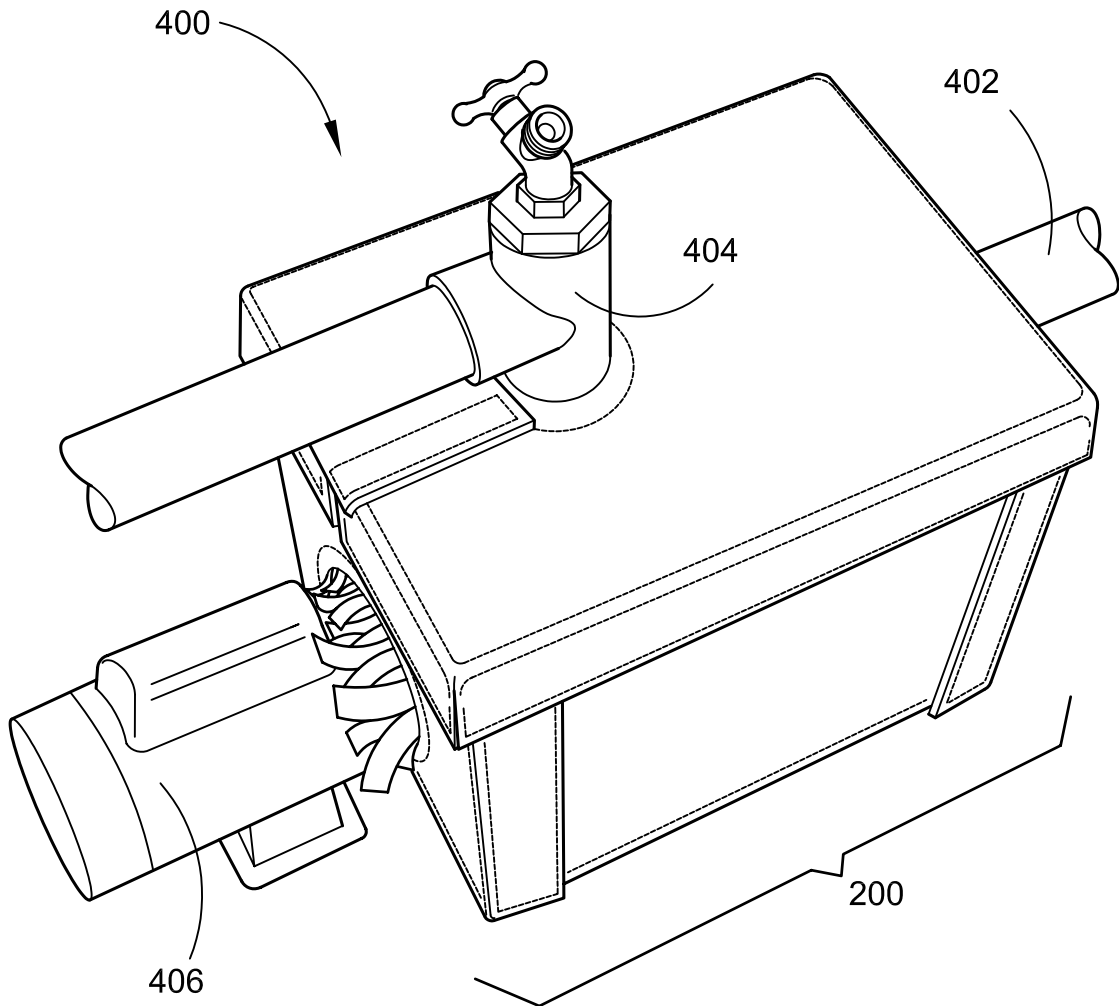
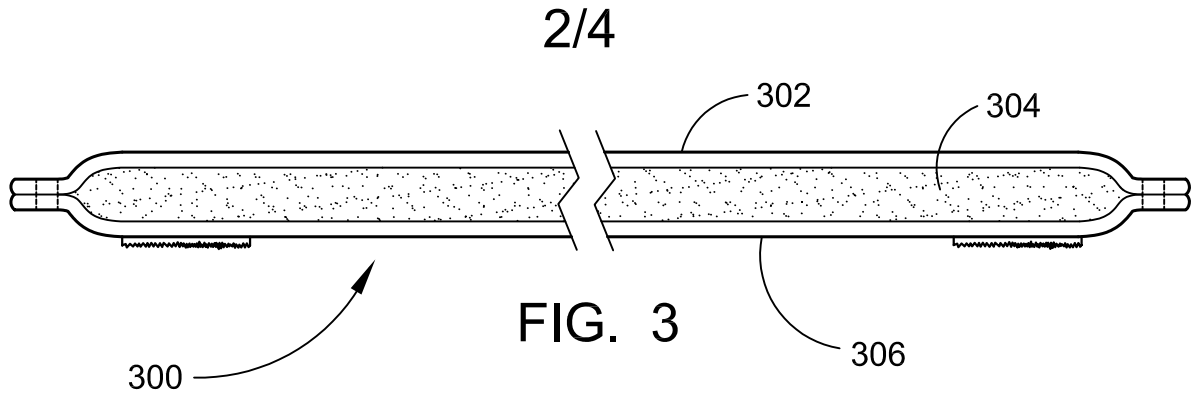

FIG. 2



3/4

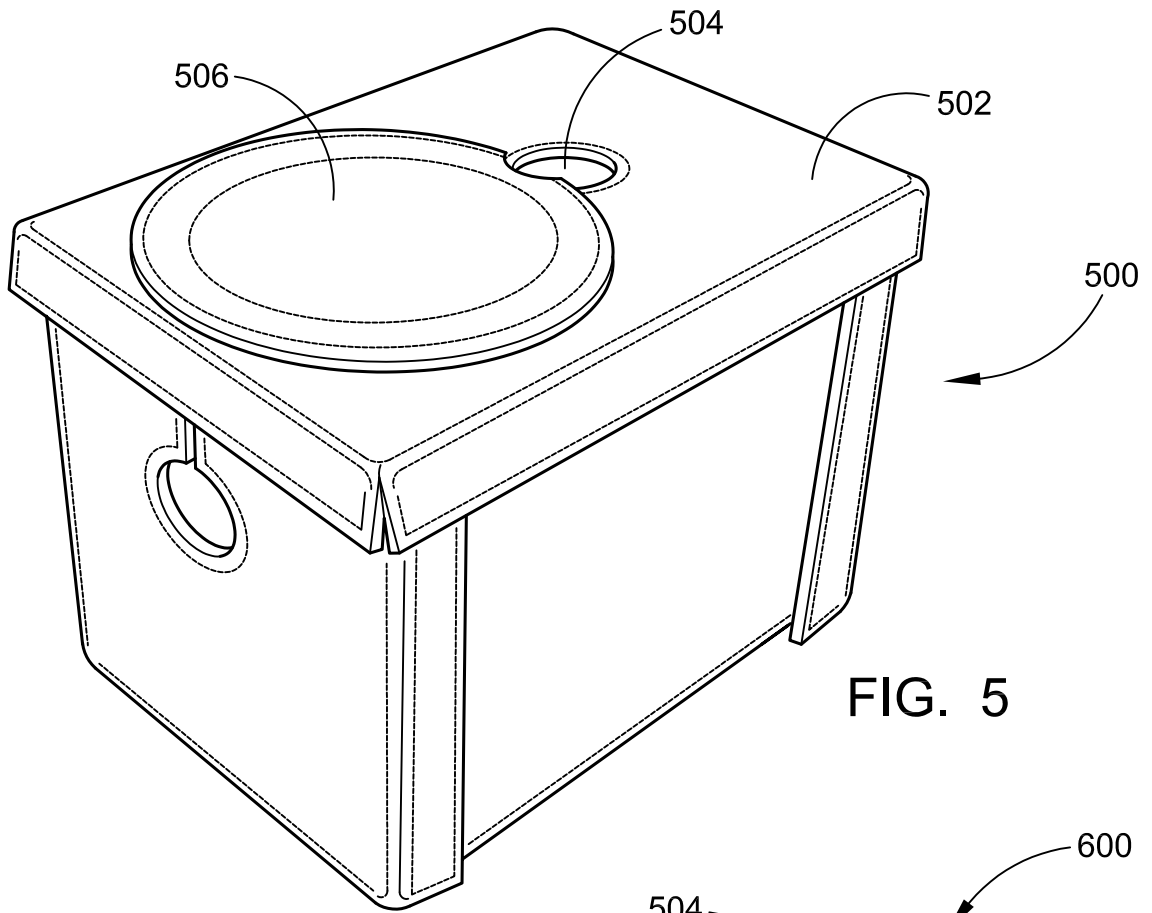

FIG. 5

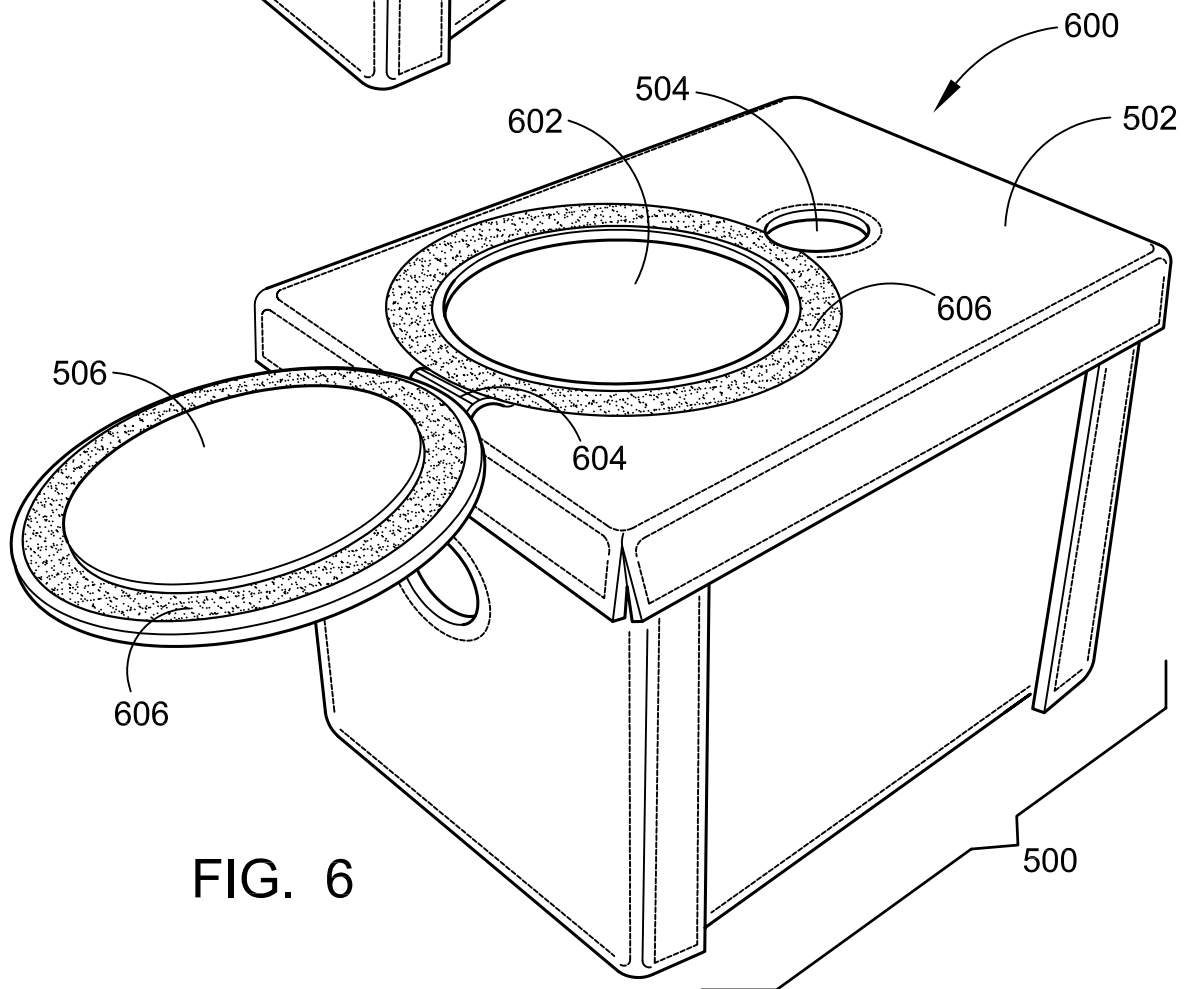

FIG. 6

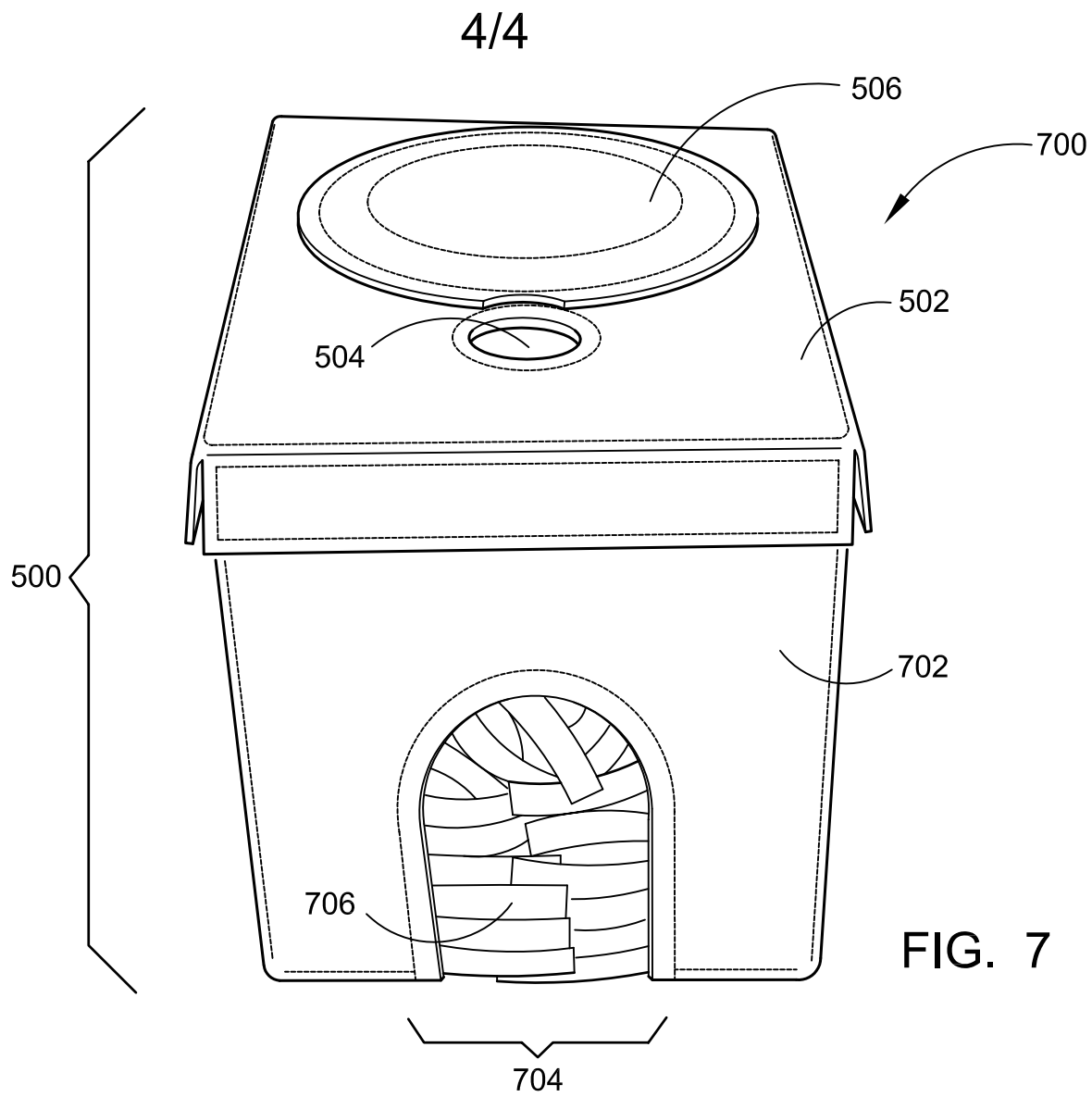

FIG. 7

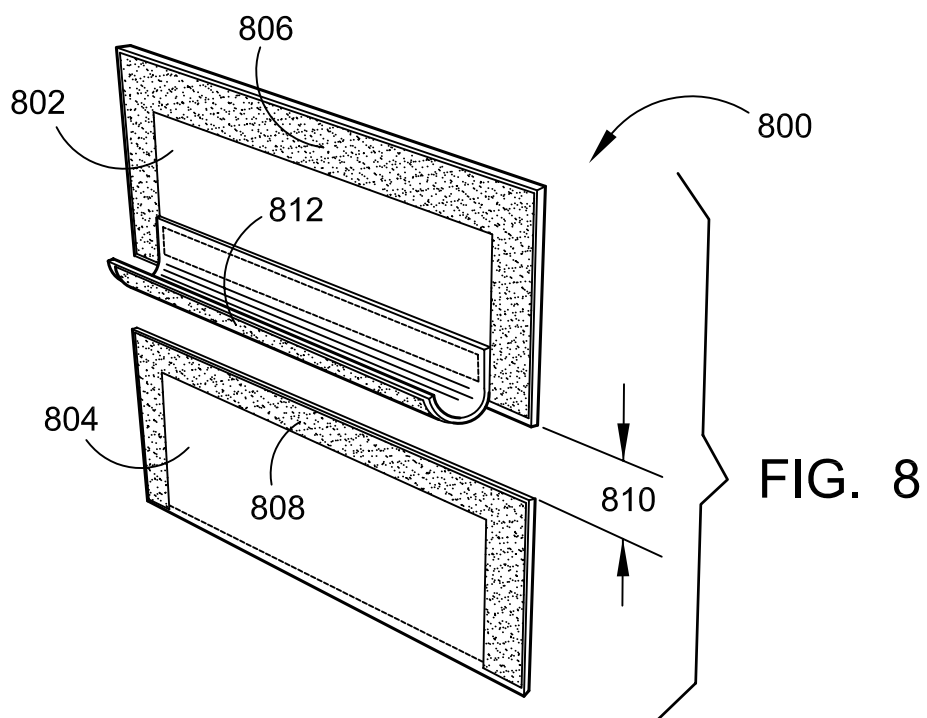

FIG. 8